

# CS222: Computer Architecture

Instructor

Dr Fatma Sakr

# Review: Instruction Formats

## R-Type

op	rs	rt	rd	shamt	funct
6 bits	5 bits	5 bits	5 bits	5 bits	6 bits

## I-Type

op	rs	rt	imm
6 bits	5 bits	5 bits	16 bits

## J-Type

op	addr
6 bits	26 bits

# R-Type

- *Register-type*
- 3 register operands:
  - rs, rt: source registers
  - rd: destination register
- Other fields:
  - op: the *operation code* or *opcode* (0 for R-type instructions)
  - funct: the *function*  
with opcode, tells computer what operation to perform
  - shamt: the *shift amount* for shift instructions, otherwise it's 0

## R-Type

op	rs	rt	rd	shamt	funct
6 bits	5 bits	5 bits	5 bits	5 bits	6 bits

# R-Type Examples

## Registers in the MIPS processor

Name	Register
\$0	0
\$at	1
\$v0-\$v1	2-3
\$a0-\$a3	4-7
\$t0-\$t7	8-15
\$s0-\$s7	16-23
\$t8-\$t9	24-25

Table B.2 R-type instructions, sorted by funct field—Cont'd

Funct	Name	Description	Operation
100000 (32)	add rd, rs, rt	add	$[rd] = [rs] + [rt]$
100001 (33)	addu rd, rs, rt	add unsigned	$[rd] = [rs] + [rt]$
100010 (34)	sub rd, rs, rt	subtract	$[rd] = [rs] - [rt]$
100011 (35)	subu rd, rs, rt	subtract unsigned	$[rd] = [rs] - [rt]$

# R-Type Examples

## Assembly Code

```
add $s0, $s1, $s2
```

```
sub $t0, $t3, $t5
```

## Field Values

op	rs	rt	rd	shamt	funct
0	17	18	16	0	32
0	11	13	8	0	34

6 bits      5 bits      5 bits      5 bits      5 bits      6 bits

## Machine Code

op	rs	rt	rd	shamt	funct	
000000	10001	10010	10000	00000	100000	(0x02328020)
000000	01011	01101	01000	00000	100010	(0x016D4022)

6 bits      5 bits      5 bits      5 bits      5 bits      6 bits

**Note** the order of registers in the assembly code:

```
add rd, rs, rt
```

# I-Type

- *Immediate-type*
- 3 operands:
  - *rs, rt*: register operands
  - *imm*: 16-bit two's complement immediate
- Other fields:
  - *op*: the opcode
  - Simplicity favors regularity: all instructions have opcode
  - Operation is completely determined by opcode

## I-Type



# I-Type Examples

Name	Register
\$0	0
\$at	1
\$v0-\$v1	2-3
\$a0-\$a3	4-7
\$t0-\$t7	8-15
\$s0-\$s7	16-23
\$t8-\$t9	24-25

---

100011 (35) lw rt, imm(rs) load word [rt] = [Address]

---

101011 (43) sw rt, imm(rs) store word [Address] = [rt]

---

---

001000 (8) addi rt, rs, imm add immediate [rt] = [rs] + SignImm

---



# I-Type Examples

## Assembly Code

```
addi $s0, $s1, 5
addi $t0, $s3, -12
lw    $t2, 32($0)
sw    $s1, 4($t1)
```

## Field Values

op	rs	rt	imm
8	17	16	5
8	19	8	-12
35	0	10	32
43	9	17	4

6 bits      5 bits      5 bits      16 bits

Name	Register
\$0	0
\$at	1
\$v0-\$v1	2-3
\$a0-\$a3	4-7
\$t0-\$t7	8-15
\$s0-\$s7	16-23
\$t8-\$t9	24-25

**Note** the differing order of registers in assembly and machine codes:

```
addi rt, rs, imm
lw    rt, imm(rs)
sw    rt, imm(rs)
```

## Machine Code

op	rs	rt	imm	
001000	10001	10000	0000 0000 0000 0101	(0x22300005)
001000	10011	01000	1111 1111 1111 0100	(0x2268FFF4)
100011	00000	01010	0000 0000 0010 0000	(0x8C0A0020)
101011	01001	10001	0000 0000 0000 0100	(0xAD310004)

6 bits      5 bits      5 bits      16 bits





# I-Type Examples

## PC-Relative Addressing

```

0x10          beq    $t0, $0, else
0x14          addi   $v0, $0, 1
0x18          addi   $sp, $sp, i
0x1C          jr     $ra
0x20          else:  addi   $a0, $a0, -1
0x24          jal   factorial

```

### Assembly Code

### Field Values

	op	rs	rt	imm	
beq \$t0, \$0, else	4	8	0	3	
(beq \$t0, \$0, 3)	6 bits	5 bits	5 bits	5 bits	6 bits

# J-Type

- *Jump-type*
- 26-bit address operand (*addr*)
- Used for jump instructions (*j*)

## J-Type

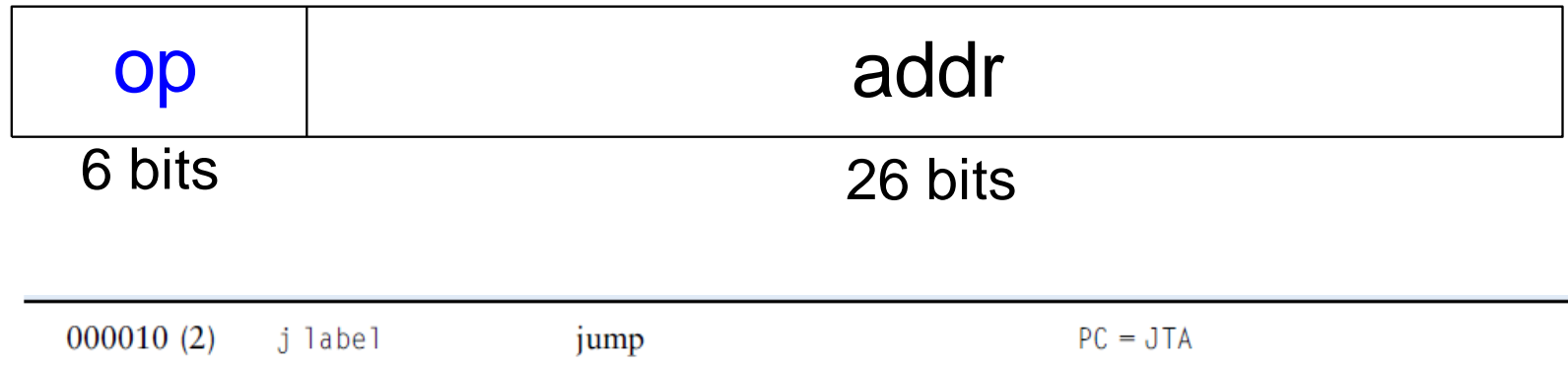

# J-Type Example

## Pseudo-direct Addressing

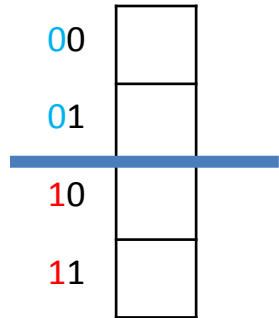

```

0x0040005C      jal    sum
...
0x004000A0  sum:  add   $v0, $a0, $a1
    
```

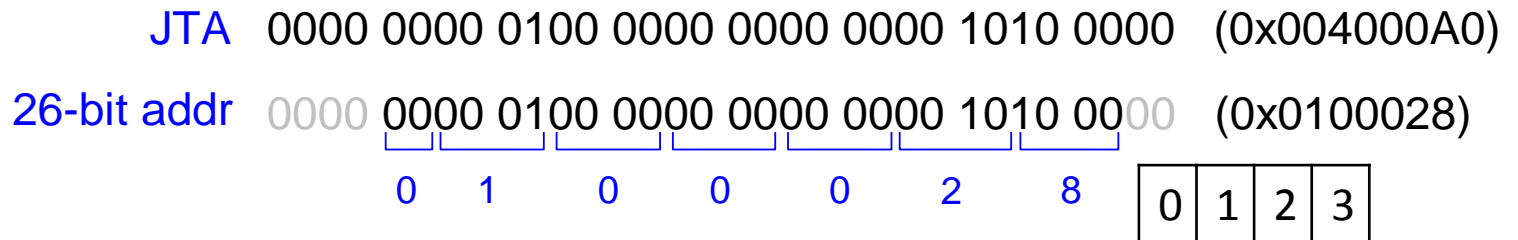

### Field Values

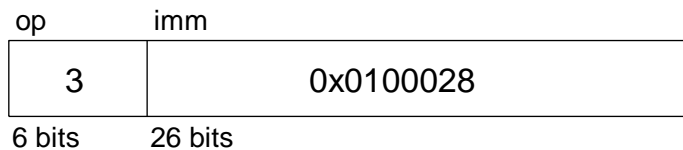

### Machine Code

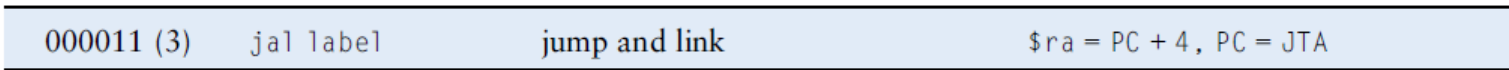
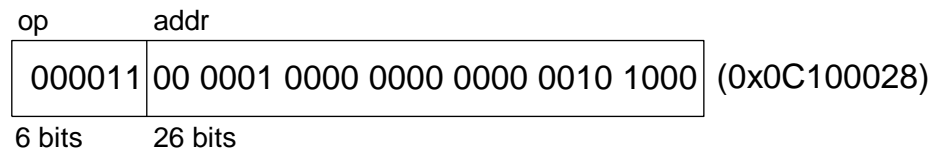

# Example Program: In Memory

Instruction	
0x23BDFFFC	addi \$sp, \$sp, -4
0xAFBF0000	sw \$ra, 0 (\$sp)
0x20040002	addi \$a0, \$0, 2
0xAF848000	sw \$a0, 0x8000 (\$gp)
0x20050003	addi \$a1, \$0, 3
0xAF858004	sw \$a1, 0x8004 (\$gp)
0x0C10000B	jal 0x0040002C
0xAF828008	sw \$v0, 0x8008 (\$gp)
0x8FBF0000	lw \$ra, 0 (\$sp)
0x23BD0004	addi \$sp, \$sp, -4
0x03E00008	jr \$ra
0x00851020	add \$v0, \$a0, \$a1
0x03E00008	jr \$ra

Data
f
g
y

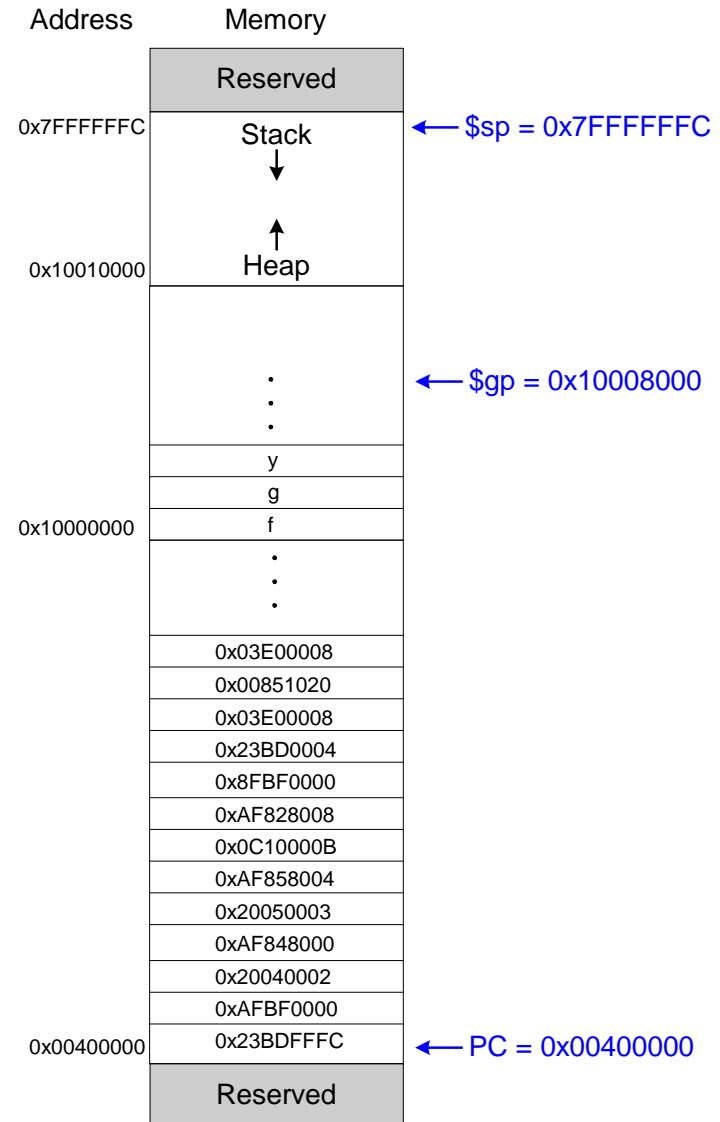

# Chapter 7





## ***Digital Design and Computer Architecture, 2<sup>nd</sup> Edition***

---

David Money Harris and Sarah L. Harris

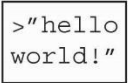
# Chapter 7 :: Topics

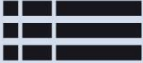
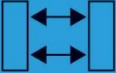
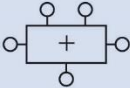
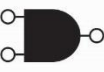
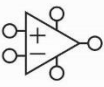
- Introduction
- Performance Analysis
- Single-Cycle Processor
- Multicycle Processor
- Pipelined Processor
- Exceptions
- Advanced Microarchitecture

Application Software	
Operating Systems	
Architecture	
<b>Micro-architecture</b>	
Logic	
Digital Circuits	
Analog Circuits	
Devices	
Physics	

# Introduction

- **Microarchitecture:** how to implement an architecture in hardware
- Processor:
  - **Datapath:** functional blocks
  - **Control:** control signals

Application Software	programs
Operating Systems	device drivers
Architecture	instructions registers
Micro-architecture	datapaths controllers
Logic	adders memories
Digital Circuits	AND gates NOT gates
Analog Circuits	amplifiers filters
Devices	transistors diodes
Physics	electrons



# Microarchitecture

- Multiple implementations for a single architecture:
  - **Single-cycle:** Each instruction executes in a single cycle
  - **Multicycle:** Each instruction is broken into series of shorter steps
  - **Pipelined:** Each instruction broken up into series of steps & multiple instructions execute at once



# Processor Performance

- Program execution time

Execution Time = (#instructions)(cycles/instruction)(seconds/cycle)

- Definitions:
  - CPI: Cycles/instruction
  - clock period: seconds/cycle
  - IPC: instructions/cycle = IPC
- Challenge is to satisfy constraints of:
  - Cost
  - Power
  - Performance

# MIPS Processor

- Consider subset of MIPS instructions:
  - R-type instructions: `and`, `or`, `add`, `sub`, `sllt`
  - Memory instructions: `lw`, `sw`
  - Branch instructions: `beq`

# Architectural State

- Determines everything about a processor:
  - PC
  - 32 registers
  - Memory

# MIPS State Elements

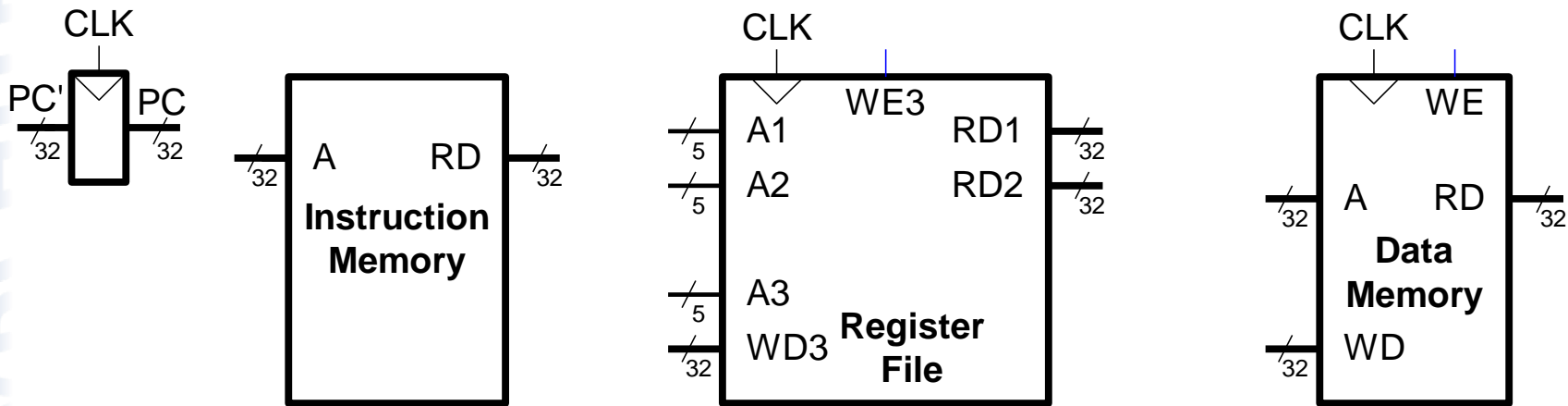

# Single-Cycle MIPS Processor

- Datapath
- Control

# Single-Cycle Datapath: $lw$ fetch

## STEP 1: Fetch instruction

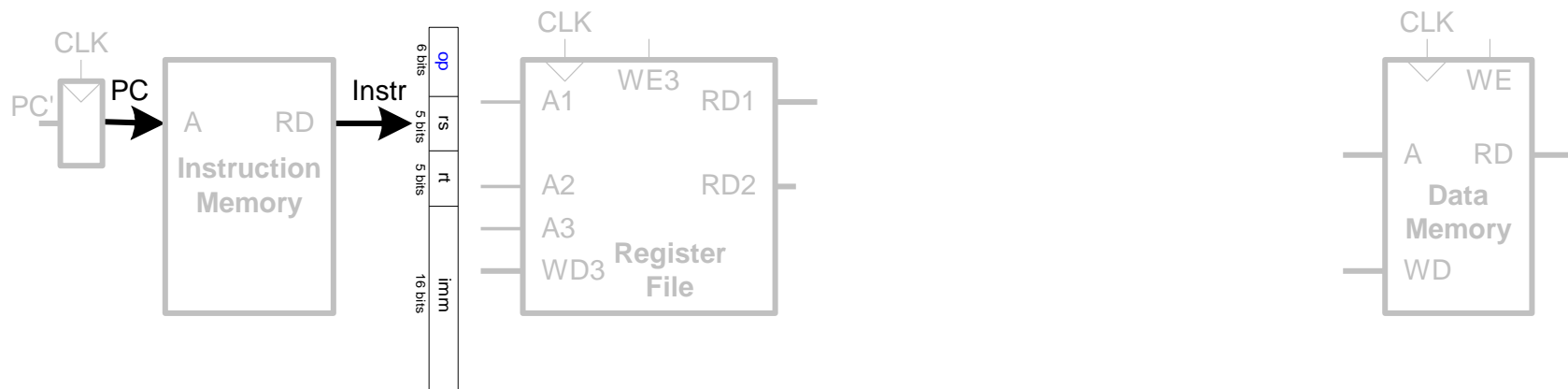

### I-Type

$lw$      $rt, imm(rs)$

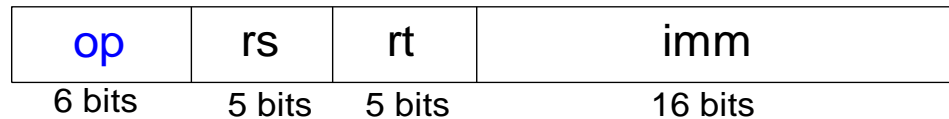

# Single-Cycle Datapath: $lw$ Register Read

## STEP 2: Read source operands from RF

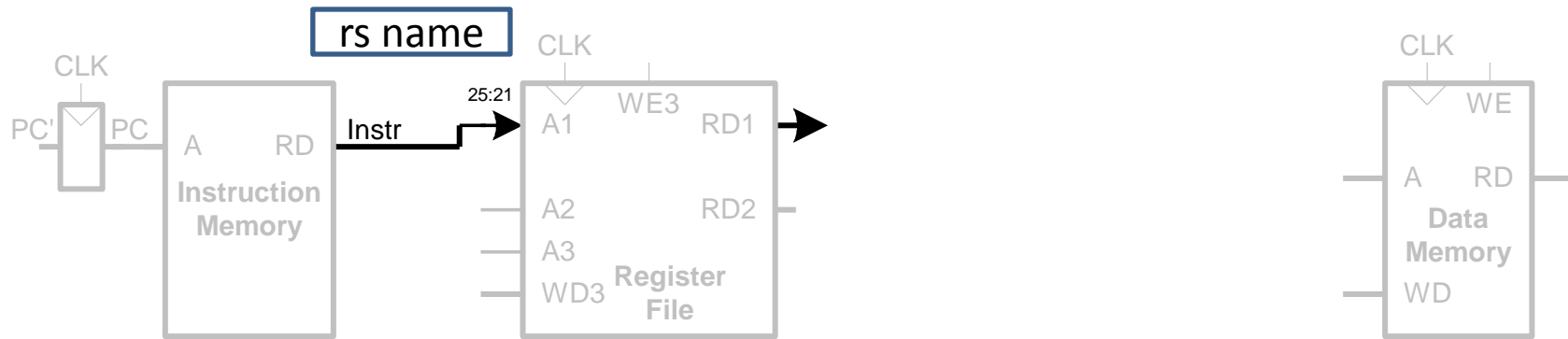

### I-Type

$lw$      $rt, imm(rs)$



# Single-Cycle Datapath: $lw$ Immediate

## STEP 3: Sign-extend the immediate

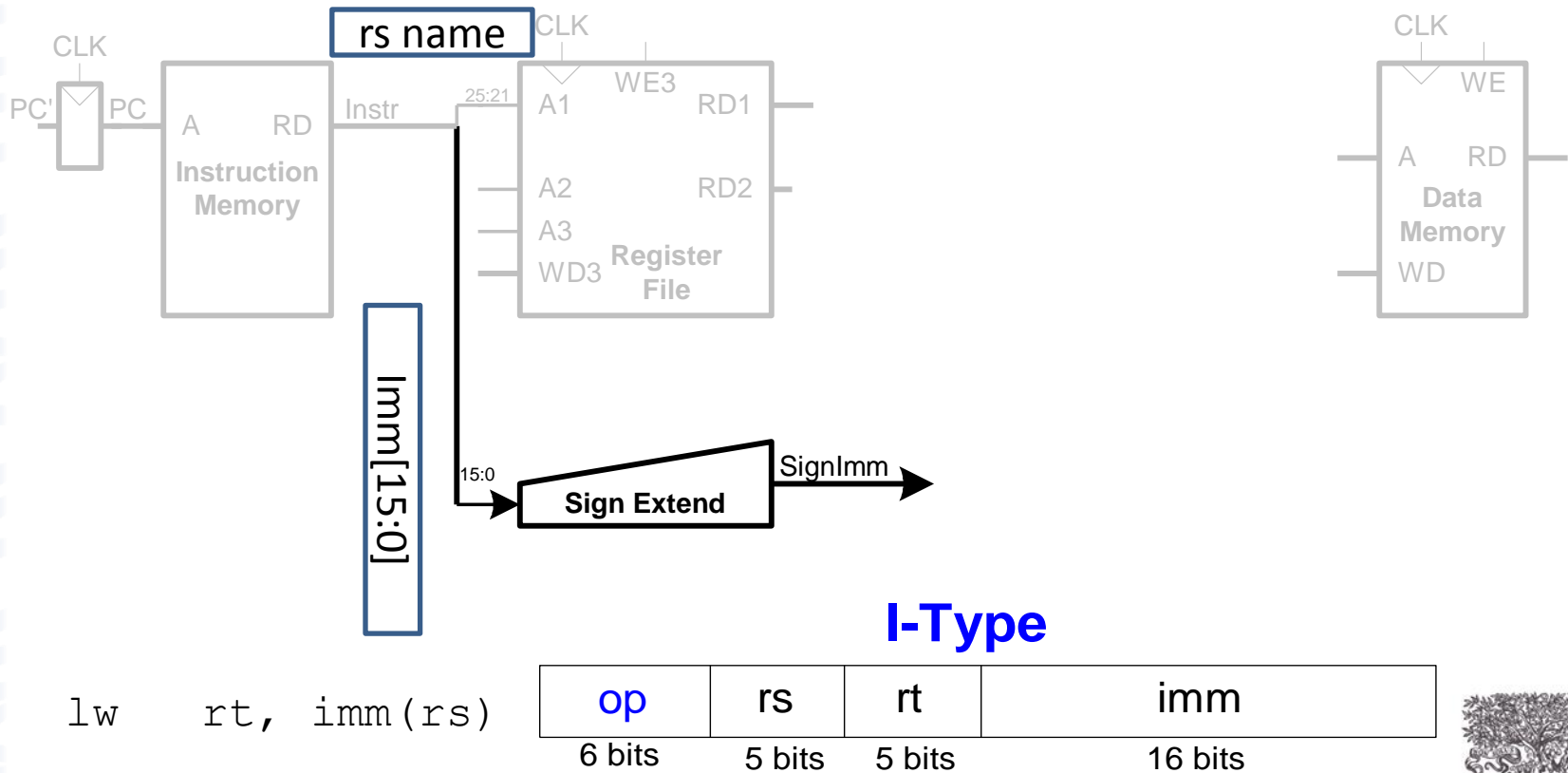



# Single-Cycle Datapath: lw address

## STEP 4: Compute the memory address

F <sub>2:0</sub>	Function
000	A & B
001	A   B
010	A + B
011	not used
100	A & ~B
101	A   ~B
110	A - B
111	SLT

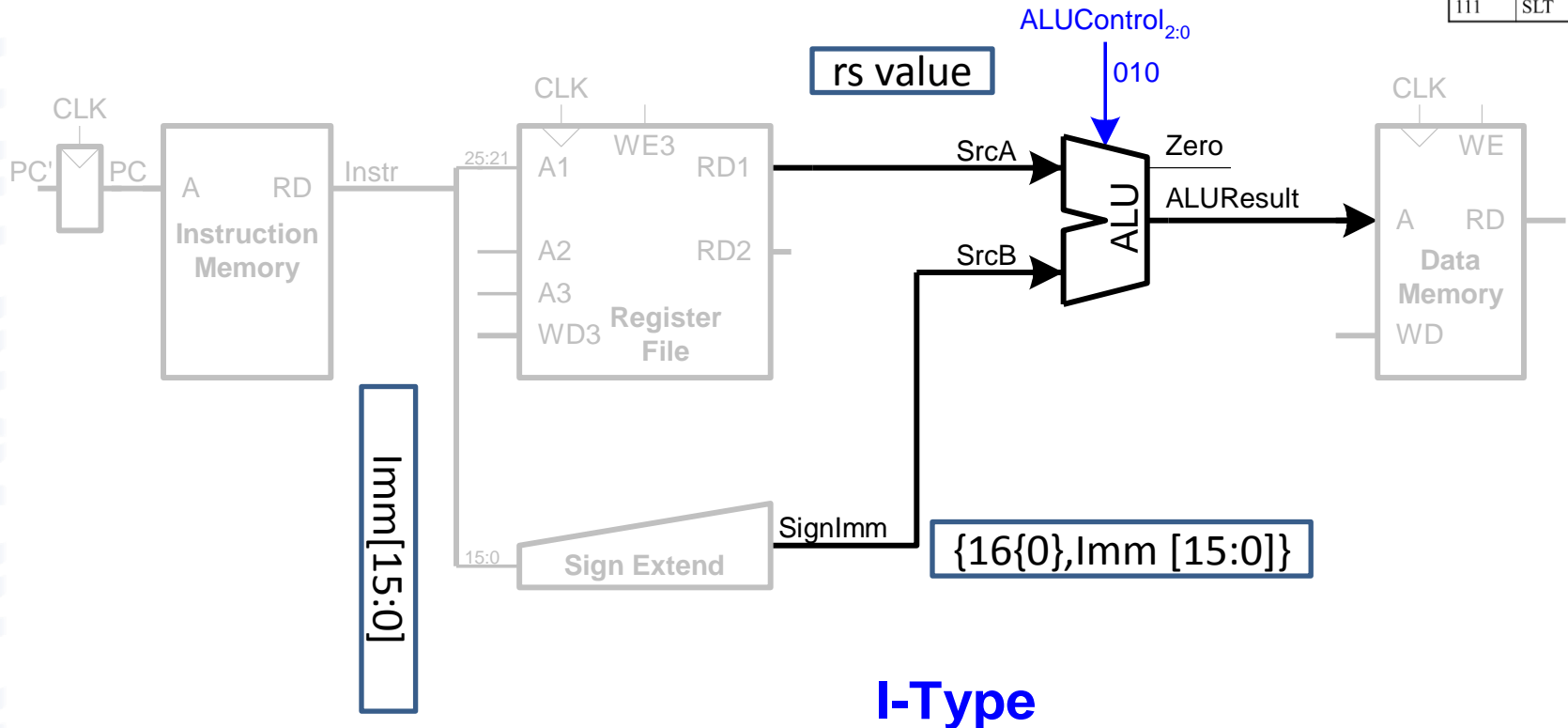

**I-Type**

`lw rt, imm(rs)`



# Single-Cycle Datapath: $lw$ Memory Read

- STEP 5:** Read data from memory and write it back to register file

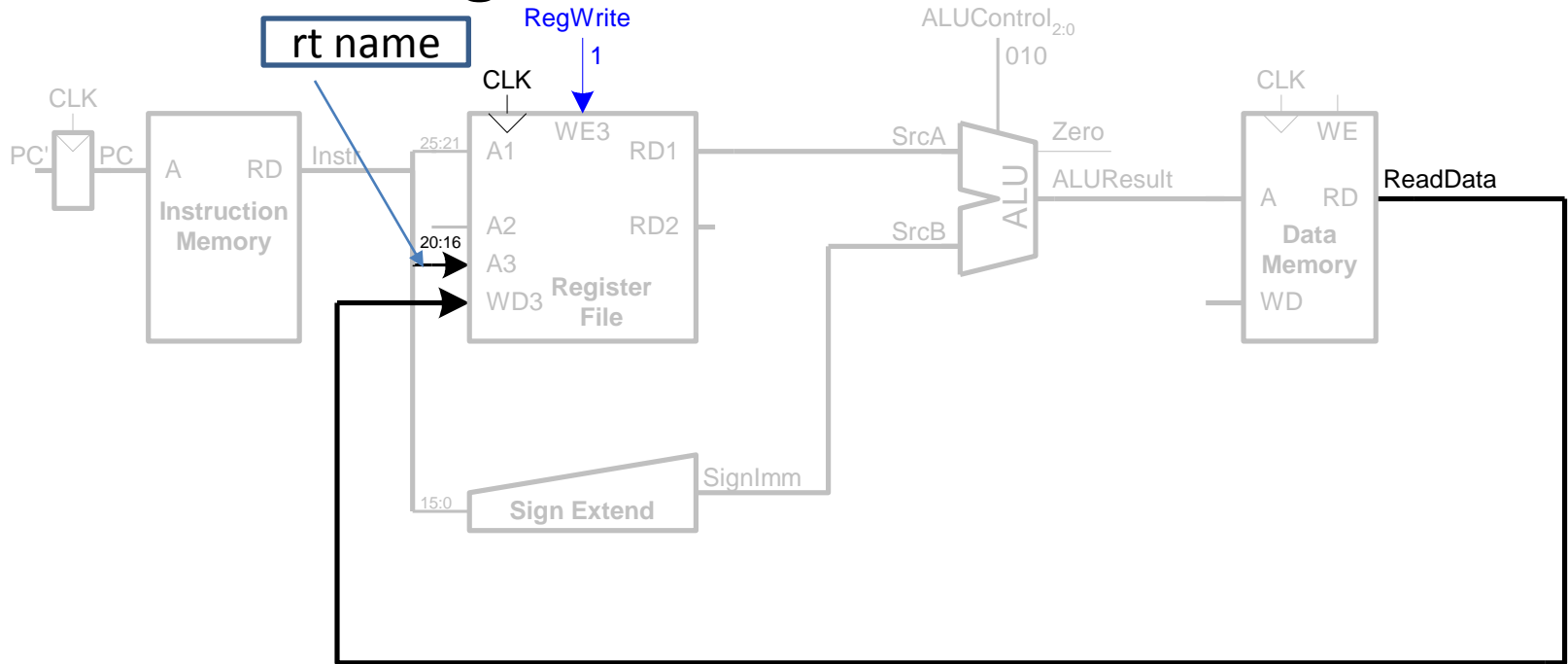

## I-Type

$lw$   $rt, imm(rs)$

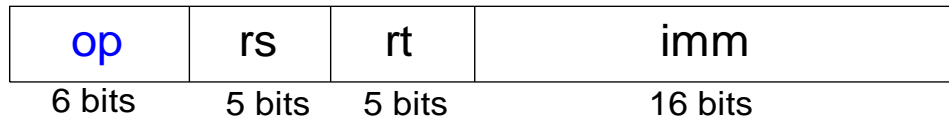

MICROARCHITECTURE



# Single-Cycle Datapath: sw

Write data in `rt` to memory

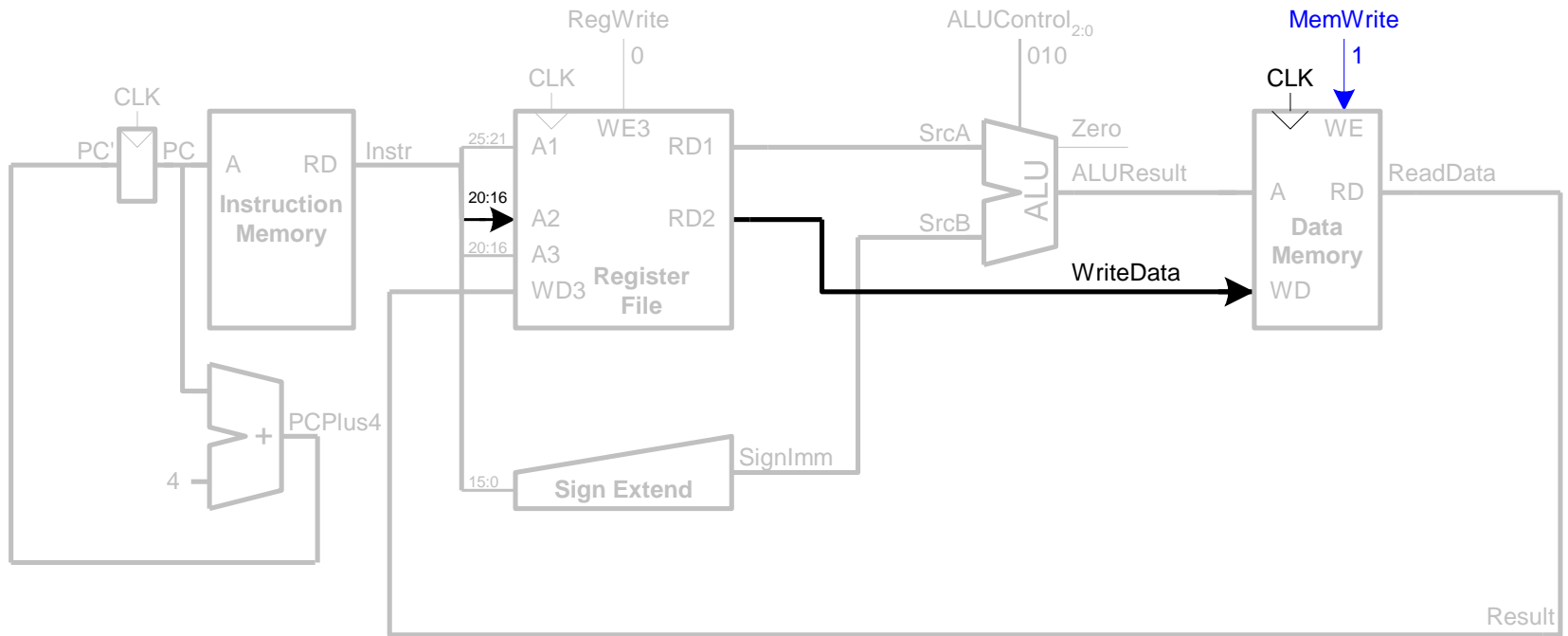

## I-Type

`sw`    `rt, imm(rs)`

<code>op</code>	<code>rs</code>	<code>rt</code>	<code>imm</code>
6 bits	5 bits	5 bits	16 bits

# Single-Cycle Datapath: R-Type

- Read from  $rs$  and  $rt$
- Write  $ALUResult$  to register file
- Write to  $rd$  (instead of  $rt$ )

## R-Type

op	rs	rt	rd	shamt	funct
6 bits	5 bits	5 bits	5 bits	5 bits	6 bits

## I-Type

op	rs	rt	imm
6 bits	5 bits	5 bits	16 bits

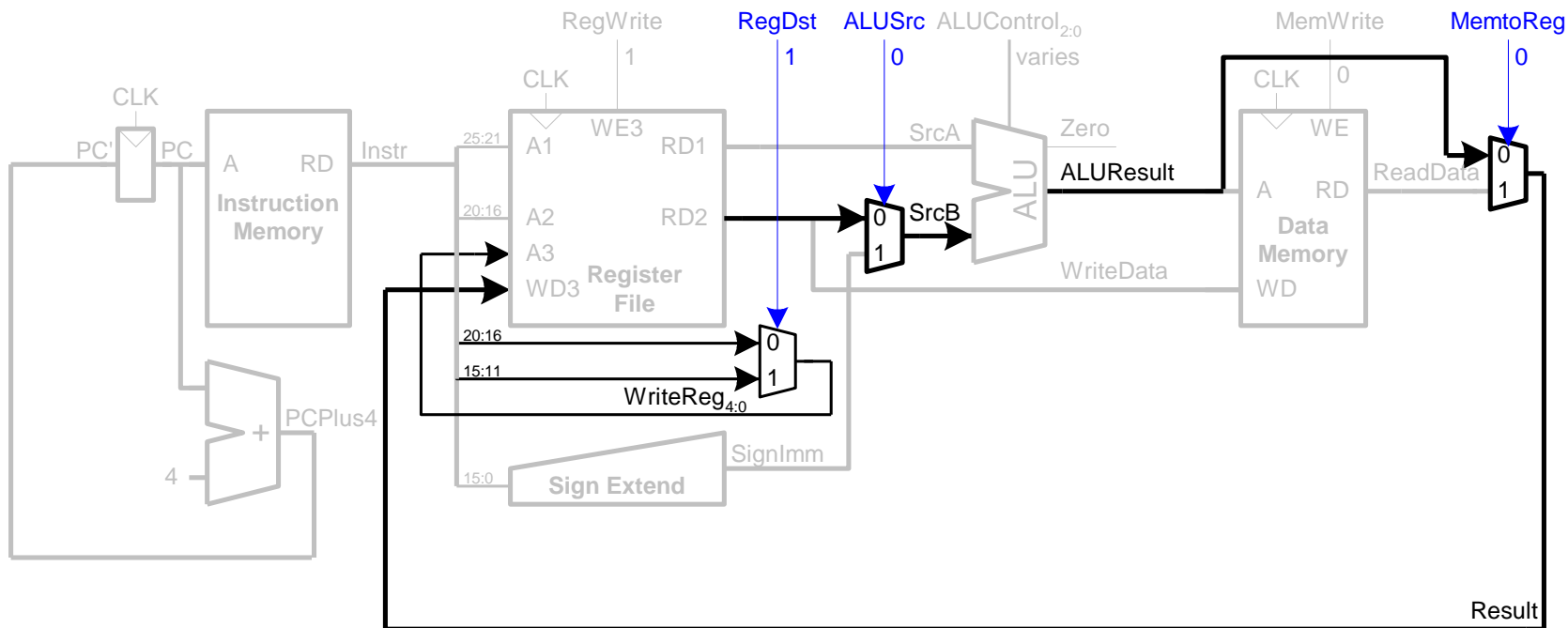

# Single-Cycle Datapath: beq

- Determine whether values in `rs` and `rt` are equal
- Calculate branch target address:

$$\text{BTA} = (\text{sign-extended immediate} \ll 2) + (\text{PC}+4)$$

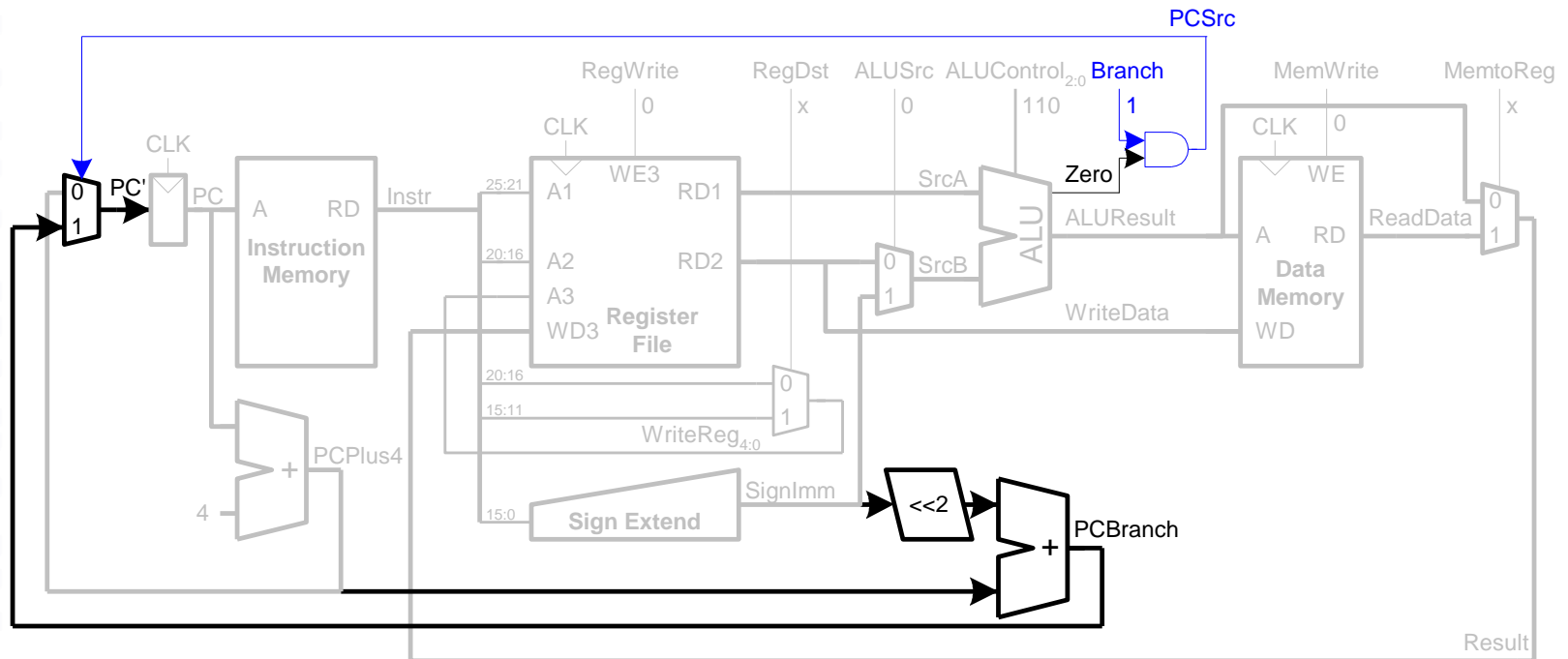

Assembly Code

```
beq $t0, $0, else
(beq $t0, $0, 3)
```

Field Values

op	rs	rt	imm
4	8	0	3
6 bits	5 bits	5 bits	5 bits



# Single-Cycle Processor

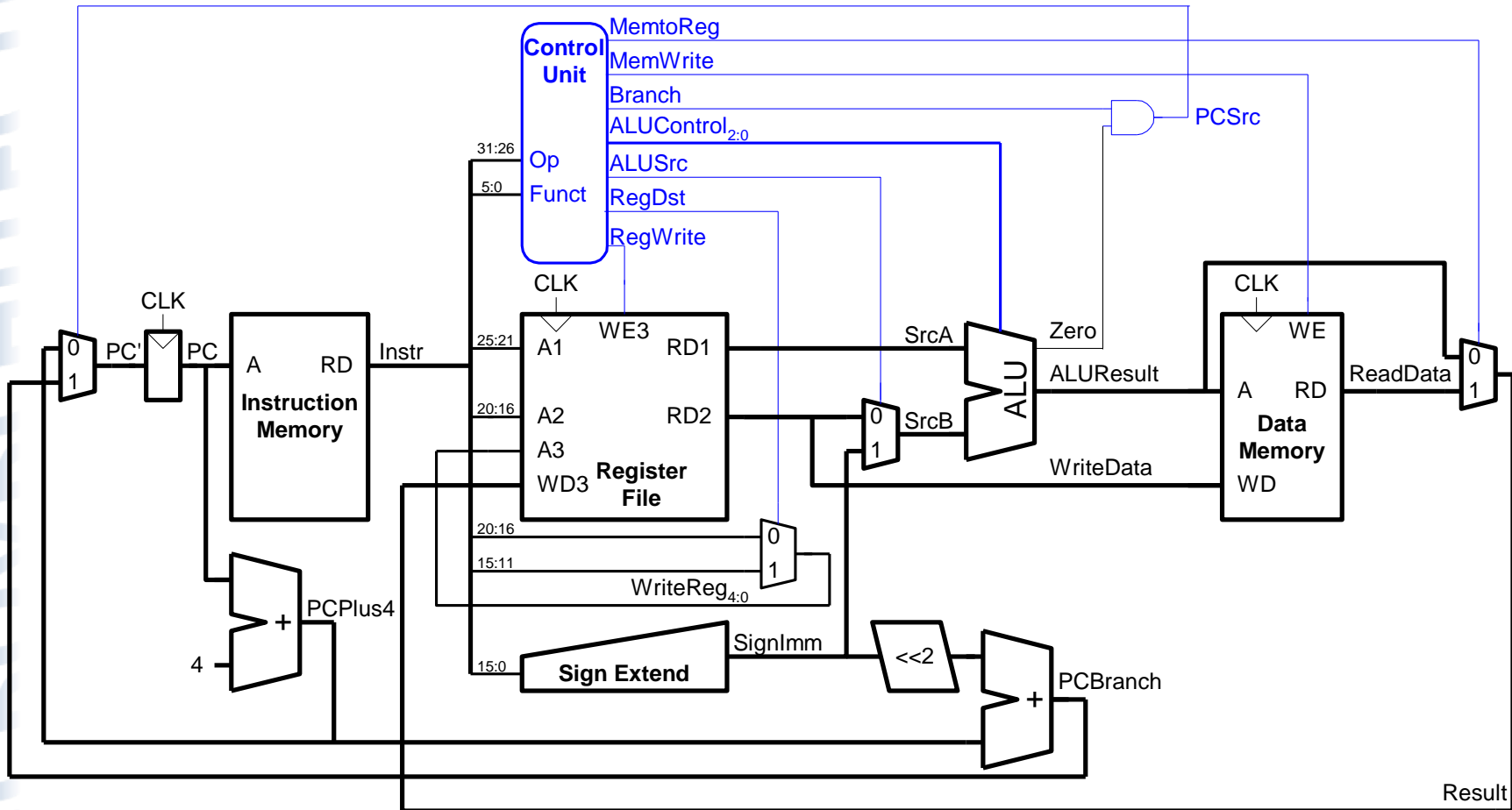

# Single-Cycle Control

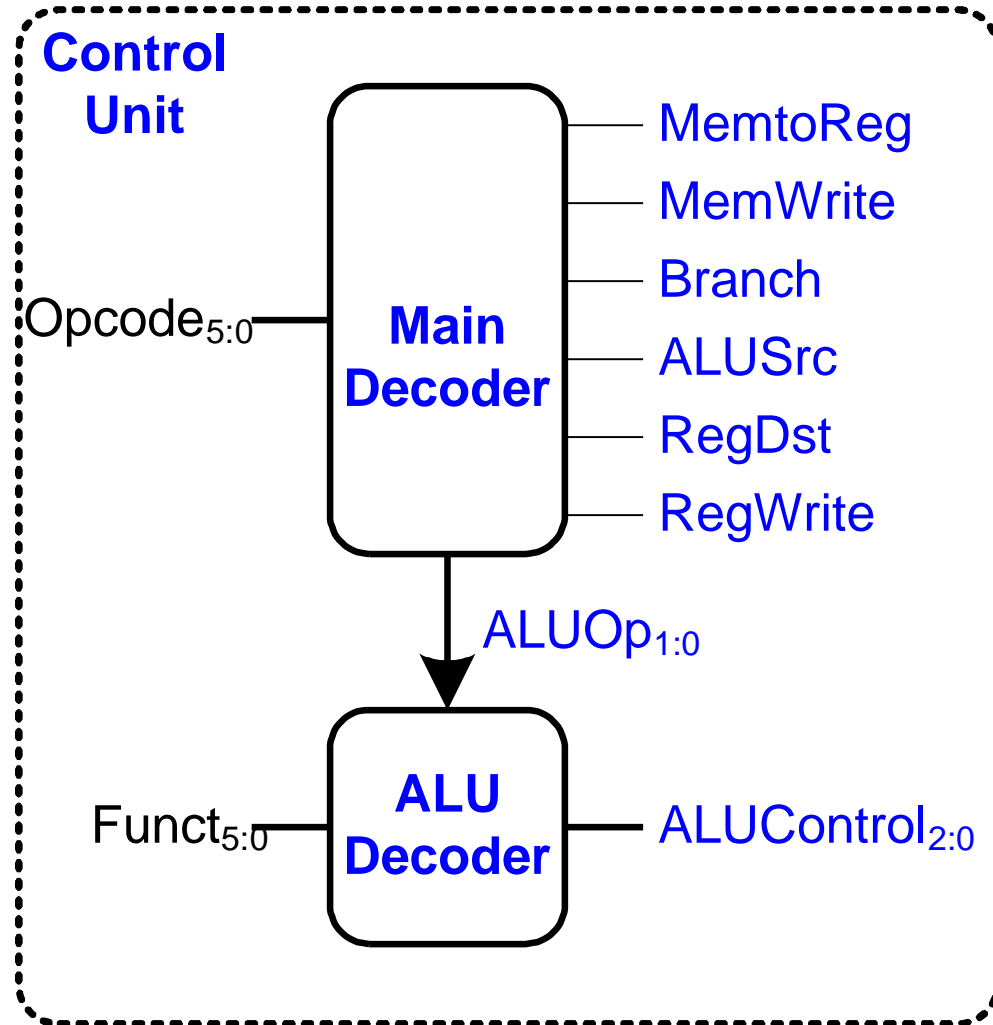



# Review: ALU

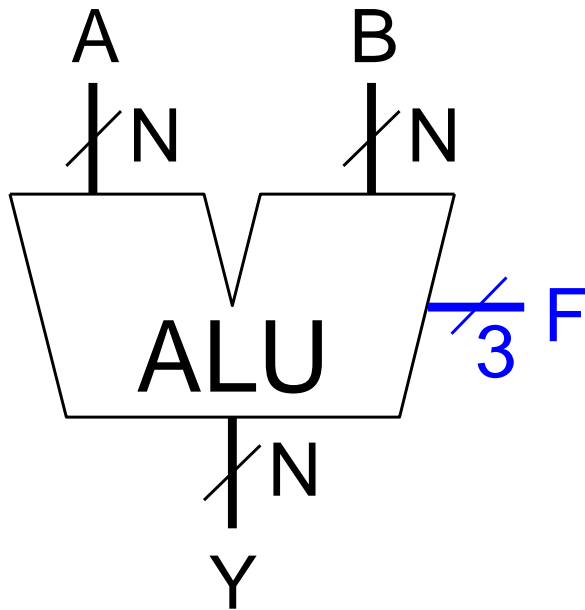

$F_{2:0}$	Function
000	A & B
001	A   B
010	A + B
011	not used
100	A & ~B
101	A   ~B
110	A - B
111	SLT



# Control Unit: ALU Decoder

ALUOp <sub>1:0</sub>	Meaning
00	Add
01	Subtract
10	Look at Funct
11	Not Used

## R-Type

op	rs	rt	rd	shamt	funct
6 bits	5 bits	5 bits	5 bits	5 bits	6 bits

ALUOp <sub>1:0</sub>	Funct	ALUControl <sub>2:0</sub>
00	X	010 (Add)
X1	X	110 (Subtract)
1X	100000 (add)	010 (Add)
1X	100010 (sub)	110 (Subtract)
1X	100100 (and)	000 (And)
1X	100101 (or)	001 (Or)
1X	101010 (slt)	111 (SLT)

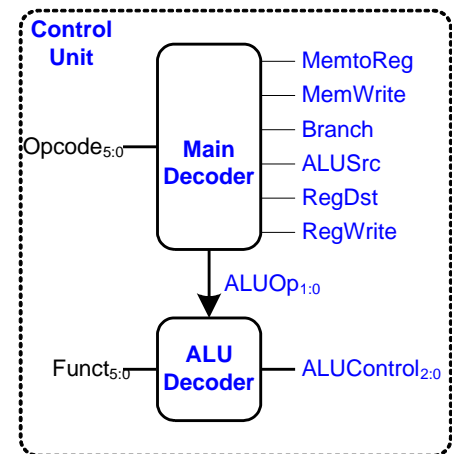

MICROARCHITECTURE

# Control Unit Main Decoder

Instruction	Op <sub>5:0</sub>	RegWrite	RegDst	AluSrc	Branch	MemWrite	MemtoReg	ALUOp <sub>1:0</sub>
R-type	000000							
lw	100011							
sw	101011							
beq	000100							

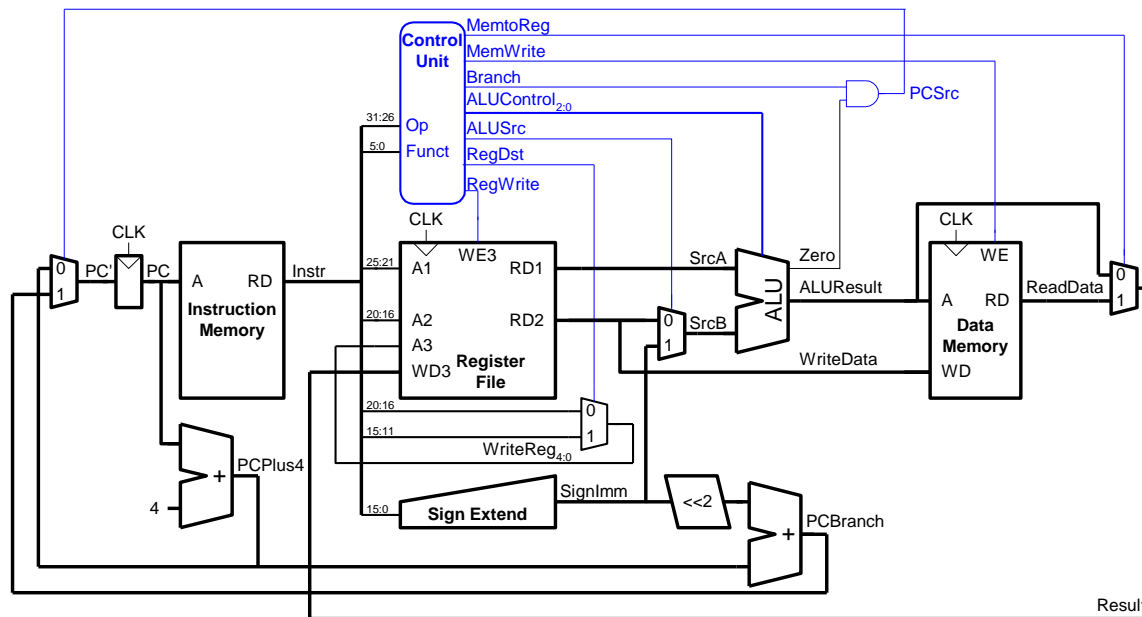

ALUOp <sub>1:0</sub>	Meaning
00	Add
01	Subtract
10	Look at Funct
11	Not Used



# Control Unit: Main Decoder

Instruction	Op <sub>5:0</sub>	RegWrite	RegDst	AluSrc	Branch	MemWrite	MemtoReg	ALUOp <sub>1:0</sub>
R-type	000000	1	1	0	0	0	0	10
lw	100011	1	0	1	0	0	1	00
sw	101011	0	X	1	0	1	X	00
beq	000100	0	X	0	1	0	X	01

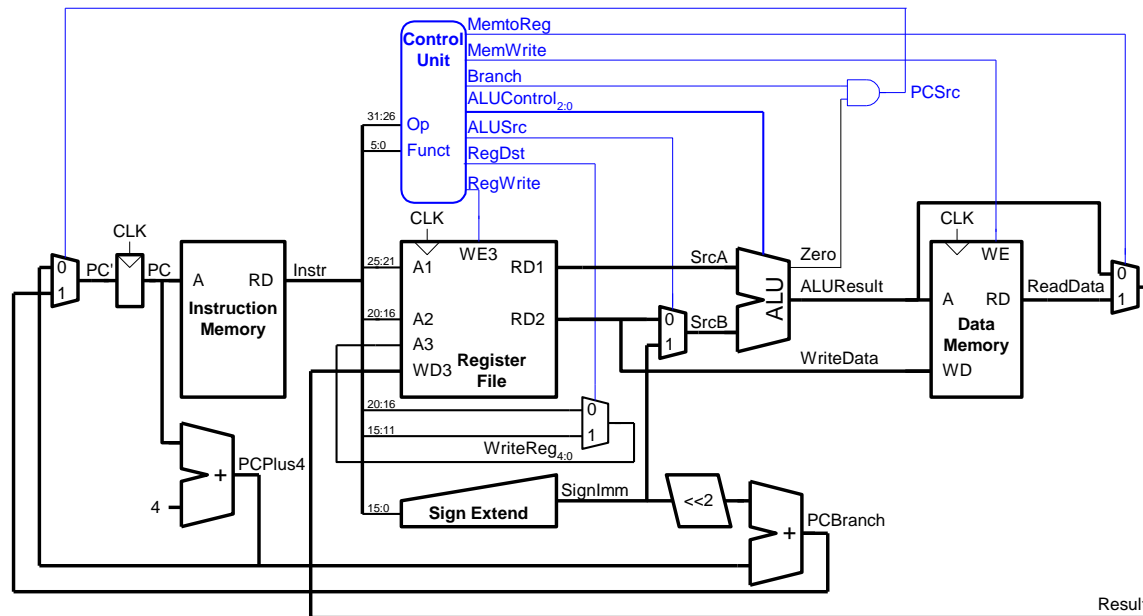

ALUOp <sub>1:0</sub>	Meaning
00	Add
01	Subtract
10	Look at Funct
11	Not Used



# Single-Cycle Datapath: or

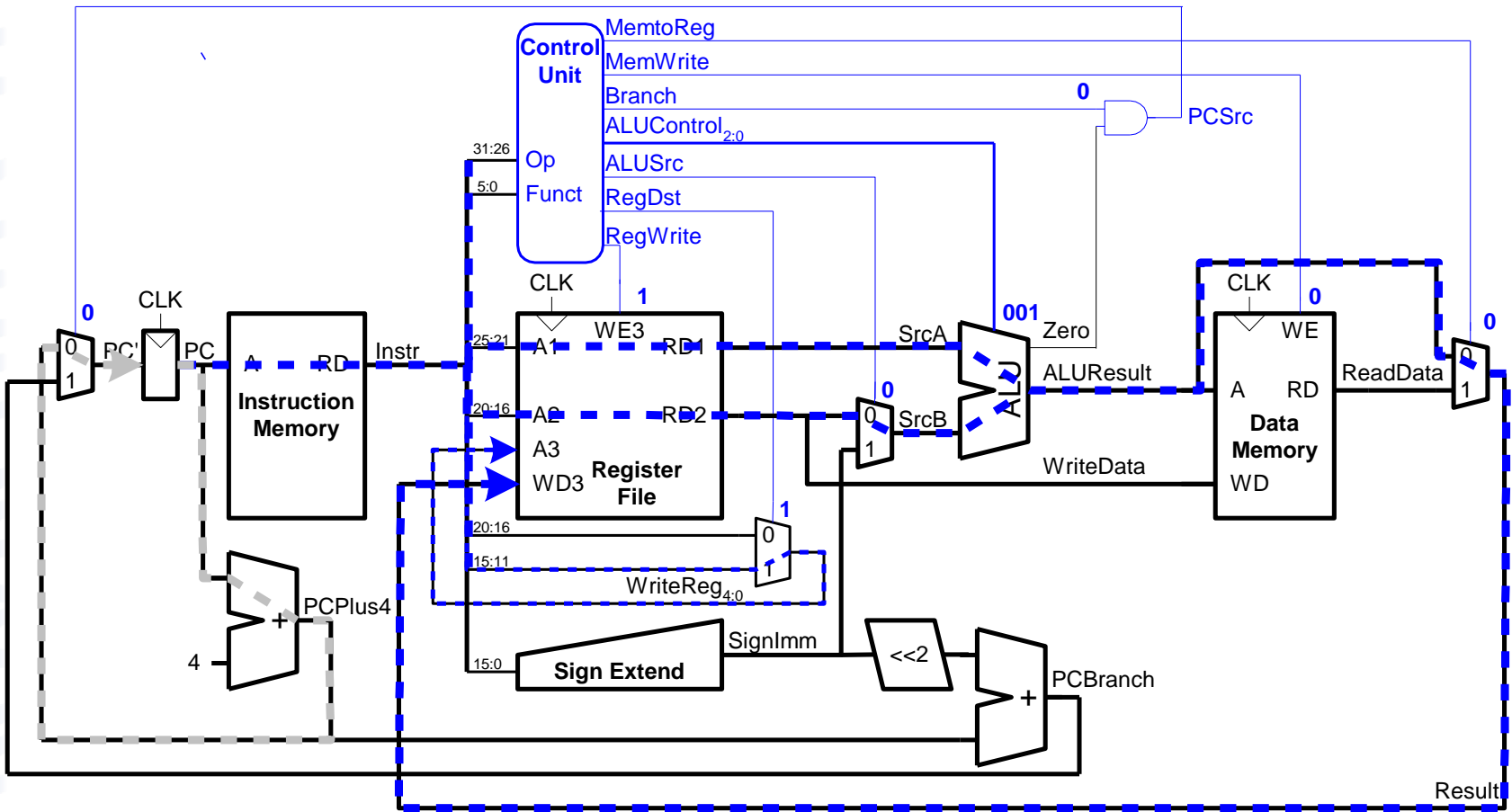

## R-Type

op	rs	rt	rd	shamt	funct
6 bits	5 bits	5 bits	5 bits	5 bits	6 bits

F <sub>2:0</sub>	Function
000	A & B
001	A   B
010	A + B
011	not used
100	A & ~B
101	A   ~B
110	A - B
111	SLT



ELSEVIER

# Extended Functionality: addi

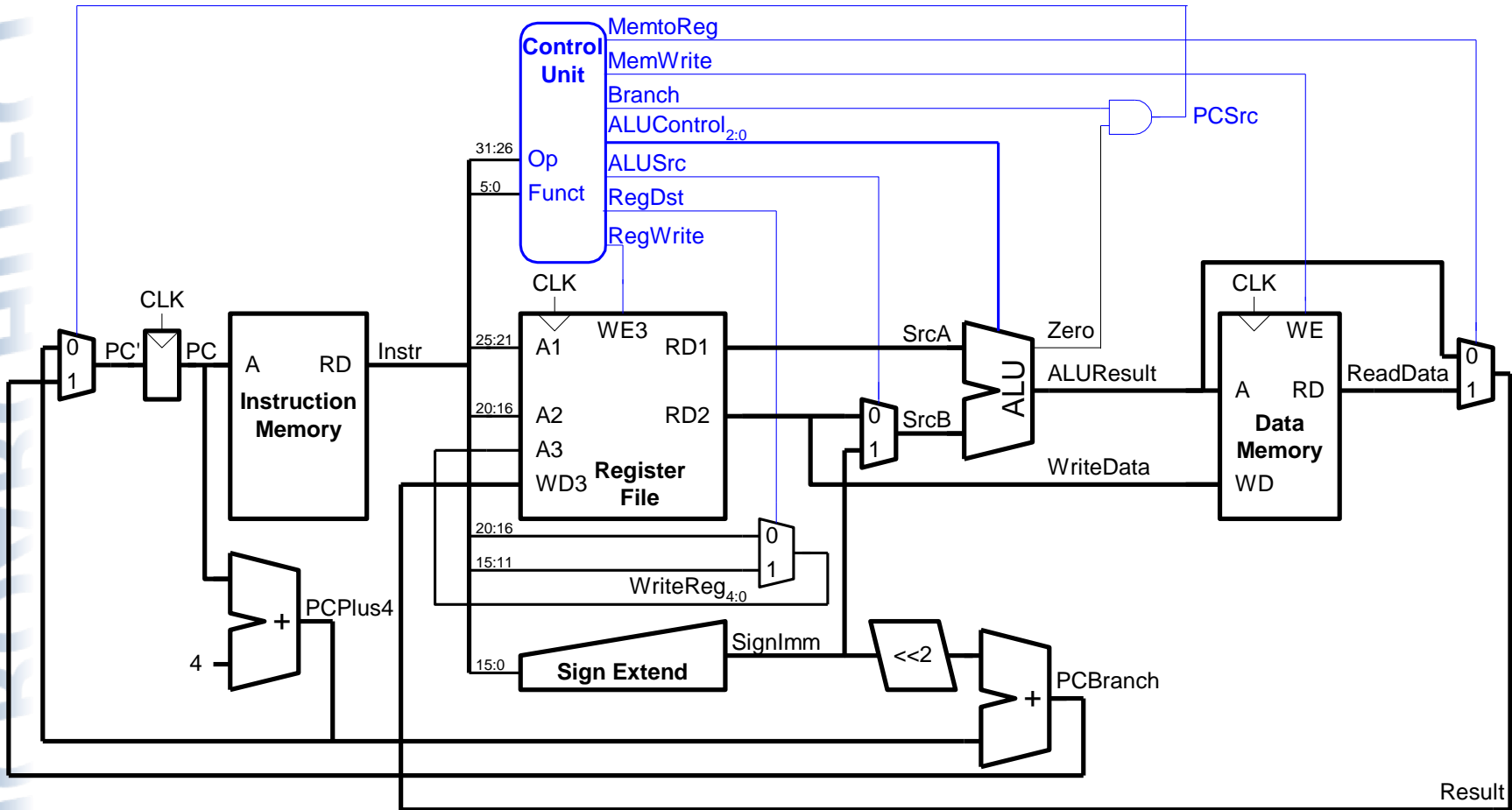

No change to datapath

# Control Unit: addi

Instruction	Op <sub>5:0</sub>	RegWrite	RegDst	AluSrc	Branch	MemWrite	MemtoReg	ALUOp <sub>1:0</sub>
R-type	000000	1	1	0	0	0	0	10
<b>addi</b>	<b>001000</b>	<b>1</b>	<b>0</b>	<b>1</b>	<b>0</b>	<b>0</b>	<b>0</b>	<b>00</b>

addi rt, rs, imm

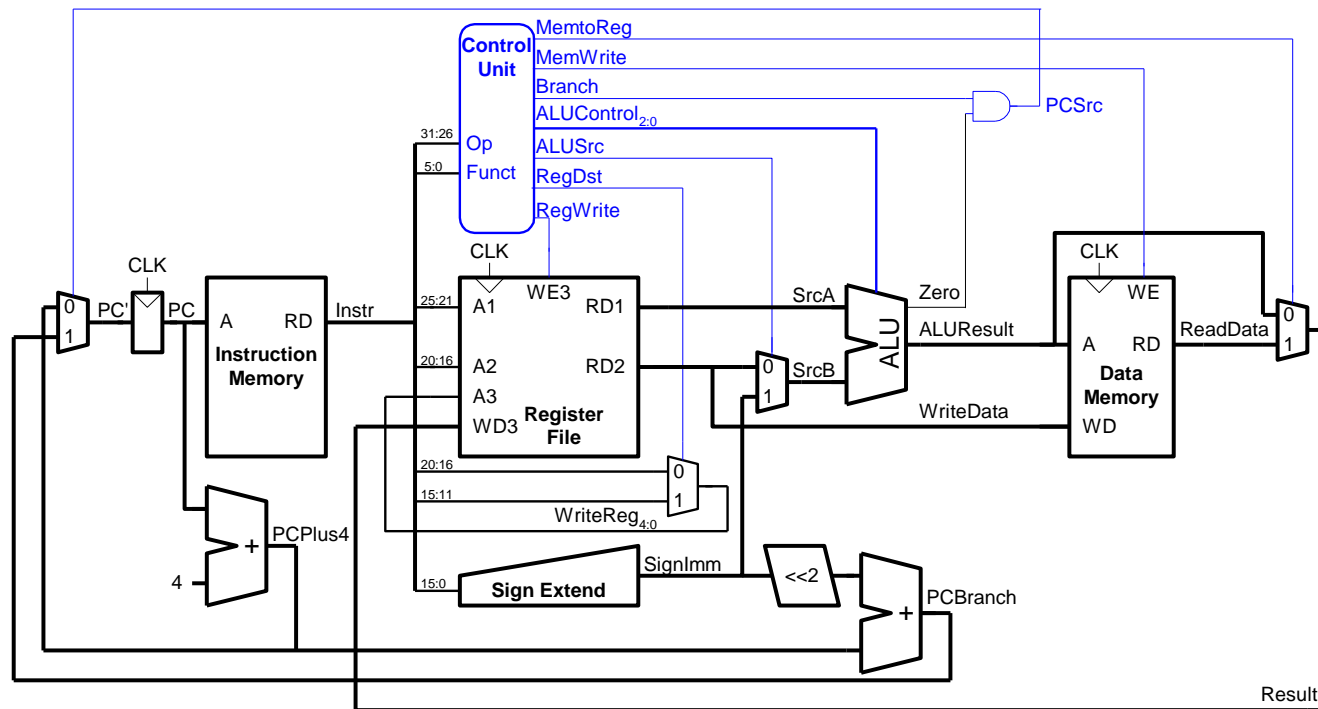



# Control Unit: addi

Instruction	Op <sub>5:0</sub>	RegWrite	RegDst	AluSrc	Branch	MemWrite	MemtoReg	ALUOp <sub>1:0</sub>
R-type	000000	1	1	0	0	0	0	10
lw	100011	1	0	1	0	0	1	00
sw	101011	0	X	1	0	1	X	00
beq	000100	0	X	0	1	0	X	01
<b>addi</b>	<b>001000</b>	<b>1</b>	<b>0</b>	<b>1</b>	<b>0</b>	<b>0</b>	<b>0</b>	<b>00</b>



# Extended Functionality: j

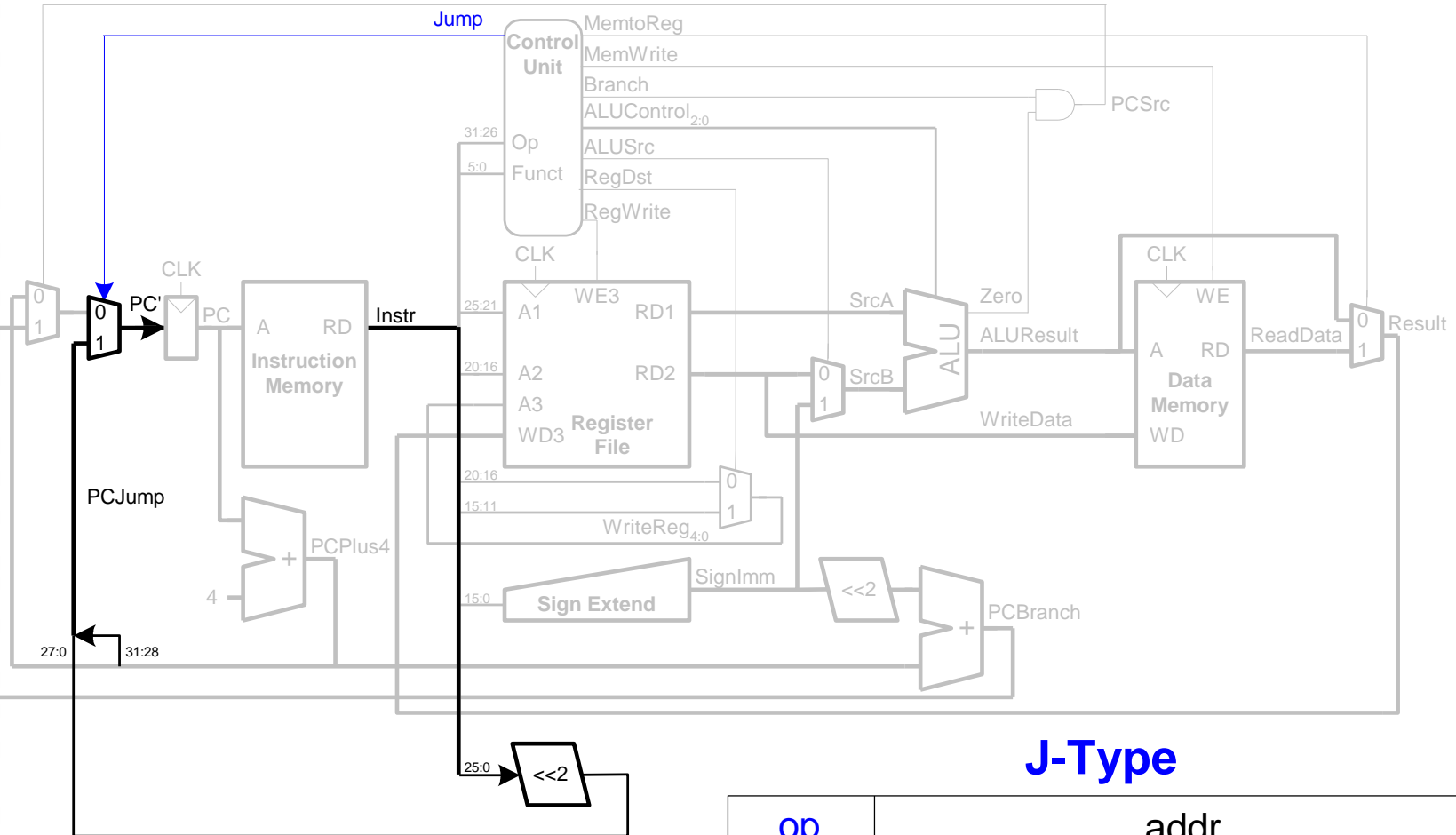

**J-Type**

# Control Unit: Main Decoder

Instruction	Op <sub>5:0</sub>	RegWrite	RegDst	AluSrc	Branch	MemWrite	MemtoReg	ALUOp <sub>1:0</sub>	Jump
R-type	000000	1	1	0	0	0	0	10	0
lw	100011	1	0	1	0	0	1	00	0
sw	101011	0	X	1	0	1	X	00	0
beq	000100	0	X	0	1	0	X	01	0
j	000010								

# Control Unit: Main Decoder

Instruction	Op <sub>5:0</sub>	RegWrite	RegDst	AluSrc	Branch	MemWrite	MemtoReg	ALUOp <sub>1:0</sub>	Jump
R-type	000000	1	1	0	0	0	0	10	0
lw	100011	1	0	1	0	0	1	00	0
sw	101011	0	X	1	0	1	X	00	0
beq	000100	0	X	0	1	0	X	01	0
j	000010	0	X	X	X	0	X	XX	1